

MODEL
CF

2500/ Oil
Burner

CF **3500**

Instruction Manual

Low/High Operation

Firing rate: CF2500A 17.0 - 19.9 GPH
CF2500 17.0 - 25.0 GPH
CF3500A 17.0 - 35.0 GPH

Motor voltage: 208/230 — 60 Hz std.



Thank you for purchasing a Beckett burner. With proper care and regular maintenance, it will provide years of trouble-free service. Please take a few minutes to read the section entitled "To the owner" inside this manual. Then, keep the manual in a safe place where it can be easily located if needed by your professional service technician.

2500/3500
Beckett

Please . . . read this page first

Hazard definitions

The following will be used throughout this manual to bring attention to hazards and their risk factors, or to special information.

DANGER Denotes presence of a hazard which, if ignored, will result in severe personal injury, death or substantial property damage.

WARNING Denotes presence of a hazard which, if ignored, could result in severe personal injury, death or substantial property damage.

CAUTION Denotes presence of a hazard which, if ignored, could result in minor personal injury or property damage.

NOTICE Intended to bring special attention to information, but not related to personal injury or property damage.

To the owner —

WARNING Installation and adjustment of the burner requires technical knowledge and the use of combustion test instruments. Do not tamper with the unit or controls. Call your qualified service technician. Incorrect operation of the burner could result in severe personal injury, death or substantial property damage.

Have your equipment inspected and adjusted at least annually by your qualified service technician to assure continued proper operation.

Never attempt to use gasoline in your heating appliance or to store gasoline or combustible materials near the heating equipment. This could result in an explosion or fire, causing severe personal injury, death or substantial property damage.

To the owner —

WARNING Never burn garbage or refuse in your heating appliance or try to light the burner by tossing burning material into the appliance. This could result in severe personal injury, death or substantial property damage.

Never attempt to use crankcase or waste oil in your heating appliance. This could damage the fuel unit or heating equipment, resulting in risk of severe personal injury, death or substantial property damage.

Never restrict air openings on the burner or to the room in which the appliance is located. This could result in fire hazard or flue gas leakage, causing severe personal injury, death or substantial property damage.

To the installer —

WARNING Read all instructions before proceeding. Follow all instructions completely. Failure to follow these instructions could result in equipment malfunction, causing severe personal injury, death or substantial property damage.

This equipment must be installed, adjusted and started only by a qualified service technician – an individual or agency, licensed and experienced with all codes and ordinances, who is responsible for the installation and adjustment of the equipment. The installation must comply with all local codes and ordinances and with the National Fire Protection Standard for Oil-Burning Equipment, NFPA 31 (or CSA B139-M91).

To the installer —

NOTICE Concealed damage - If you discover damage to the burner or controls during unpacking, notify the carrier at once and file the appropriate claim.

Contacting Beckett for service information or parts - Please record the burner serial number (and have available when calling or writing). You will find the serial number on the Underwriters Laboratories label, located on the left rear of the burner.

NOTICE **50 Hz motors** — The burner ratings, air settings and nozzle ratings are based on standard 60 hz motors (at 3450 rpm). Derate all ratings 20% when using 50 hz motors. Consult factory for specific application data.

NOTICE **High altitude installations** — Accepted industry practice requires no derate of burner capacity up to 2,000 feet above sea level. For altitudes higher than 2,000 feet, derate burner capacity 4% for each 1000 feet above sea level.

Warranty

Beckett warrants its equipment to those who have purchased it for resale, including your dealer. If you have any problems with your equipment or its installation, you should contact your dealer for assistance.

Specifications

Fuels	#1 or #2 Fuel Oil
Firing range	CF2500A 17.0 - 19.9 GPH CF2500 17.0 - 25.0 GPH CF3500A 17.0 - 35.0 GPH
Motor	2 HP 3450 RPM 208/230/60 hz/1-PH std. 13.4 amps @ 230 VAC Optional voltages: (60 hz <i>or</i> 50 hz) – • 208/230/480/3-PH
Ignition Trans.	120V/12,000V
Housing	Cast aluminum
Fuel unit	100 - 300 PSIG
Oil nozzle	45° - 70° solid
Shipping wt.	106 lbs.
Dimensions	See Figure 7 (Page 7)

(See **NOTICE** on opposite page for **50 hz** motor applications.)

Agency approvals

- Underwriters Laboratories has certified this burner to comply with ANSI Standard 296 and has listed it for use with No. 1 or No. 2 fuel oil as specified in ASTM D396. State and local approvals appear on the burner rating label.
- Certified by ULC.
- Approved by Commonwealth of Massachusetts - State Fire Marshall.
- Accepted by N.Y.C. M.E.A.
- Other approvals may be available and must be specified at time of order.

Contents

Please . . . read this page first	2
Pre-installation checklist.....	4
Mount the burner	6
Connect fuel line(s).....	8
Wire the burner	10
Sequence of operation - typical	11
Prepare the burner for start-up.....	11
Start the burner	14
Maintenance and service.....	15
Replacement parts.....	Back cover

Before you begin . . .

The following resources will give you additional information for your installation. We suggest that you consult these resources whenever possible. Pay particular attention to the appliance manufacturer's instructions.

Appliance manufacturer's instructions — Always follow the appliance manufacturer's instructions for burner installation, equipment and setup.

1-800-OIL-BURN — Beckett's technical services hot-line.

www.beckettcorp.com — Beckett's website.

Pre-installation checklist

❑ Combustion air supply

- The burner requires combustion air and ventilation air for reliable operation. Assure that the building and/or combustion air openings comply with National Fire Protection Standard for Oil-Burning Equipment, NFPA 31. For appliance/burner units in confined spaces, the room must have an air opening near the top of the room plus one near the floor, each with a free area at least one square inch per 1,000 Btu/hr input of all fuel burning equipment in the room. For other conditions, refer to NFPA 31 (CSA B1139-M91 in Canada).
- If there is a risk of the space being under negative pressure or of exhaust fans or other devices depleting available air for combustion and ventilation, the appliance/burner should be installed in an isolated room provided with outside combustion air.

❑ Clearances

- With the burner installed in the appliance, there must be adequate space in front of and on the sides of the burner to allow access and operation. Verify that the clearance dimensions comply with all local codes and with the appliance manufacturer's recommendations.

❑ Fuel supply

- The fuel supply piping and tank must provide #1 or #2 fuel oil at pressure or vacuum conditions suitable for the fuel unit (oil pump) on the burner. Refer to fuel unit literature in the literature envelope in the burner carton to verify allowable suction pressure.

WARNING

The fuel unit is shipped without the by-pass plug installed. You **must** install this plug on two-pipe system. **DO NOT** install the by-pass plug in the fuel unit if connected to a one-pipe oil system. Failure to comply could cause fuel unit seal failure, oil leakage and potential fire and injury hazard.

When fuel supply is level with or higher than burner fuel unit —

- When the fuel unit is not required to lift the oil, the installation is usually suitable for either a one-pipe or two-pipe oil system. The oil pressure at the inlet of the fuel unit must not exceed 3 psig.
- See **Figure 8** for one-pipe fuel supply installations. See **Figure 9** for two-pipe fuel supply installations.

When fuel supply is below the burner fuel unit —

- Use a two-pipe oil system when the fuel unit must lift the oil more than 2 feet. The return line provided by the two-pipe system is needed to purge the air from the fuel lines and minimize the likelihood of air-related problems during operation.

❑ Vent system

- The flue gas venting system must be in good condition and must comply with all applicable codes.

❑ Electrical supply

- Verify that the power connections available are correct for the burner. All power must be supplied through fused disconnect switches.

❑ Verify burner components —

- **Burner box**, Model CF2500A/CF2500/CF3500A
- **Air tube assembly** (selected per following)
- **Mounting flange kit**
- **Pedestal mounting assembly kit** (recommended)
- **Oil nozzle**, per **Table 1** — Use only 45° to 70° solid pattern nozzles unless otherwise shown by appliance manufacturer.
The CF2500A, CF2500 and CF3500A are dual nozzle burners. To select the nozzles, use half of the maximum firing rate and select a nozzle under the 300 psig column (high fire rate). Select the corresponding nozzle from column 1 (**Rated gph @ 100 psig**). Two nozzles will be required.

Table 1 - Nozzle capacities at various pressures

Rated gph @ 100 psig	Pressure - pounds per square inch					
	125	150	175	200	250	300
5.00	5.59	6.13	6.61	7.07	7.50	8.66
5.50	6.15	6.74	7.27	7.78	8.70	9.54
6.00	6.71	7.33	7.94	8.48	9.49	10.40
6.50	7.26	7.96	8.60	9.20	10.30	11.25
7.00	7.82	8.56	9.25	9.90	11.06	12.12
7.50	8.38	9.19	9.91	10.60	11.85	13.00
8.00	8.94	9.80	10.58	11.31	12.65	13.85
8.50	9.50	10.45	11.27	12.06	13.40	14.70
9.00	10.06	11.02	11.91	12.73	14.20	15.60
9.50	10.60	11.70	12.60	13.50	15.00	16.45
10.00	11.18	12.25	13.23	14.14	15.81	17.32
10.50	11.74	12.85	13.90	14.85	16.60	18.18
11.00	12.30	13.47	14.56	15.55	17.39	19.05
11.50	12.85	14.08	15.22	16.26	18.18	19.92
12.00	13.42	14.70	15.87	16.97	18.97	20.78
12.50	13.98	15.31	16.54	17.68	19.76	21.65
13.00	14.54	15.92	17.20	18.38	20.55	22.52
13.50	15.10	16.53	17.85	19.09	21.34	23.38

Verify firing rate

- Refer to appliance manufacturer's instructions (if available) for firing rate and nozzle selection. Otherwise, the maximum recommended firing rate for the burner depends on the length of the firing chamber and the distance from the burner center to the chamber floor. Verify that the chamber dimensions are at least as large as the minimum values given in **Figure 1**. If the appliance dimensions are smaller than recommended, reduce the firing rate accordingly.

Verify air tube

- The information in this section may be disregarded if the air tube is supplied by the appliance manufacturer.
- The following tube arrangements are available:
 - Model CF2500A:** Tube **KP** — 17.0 to 19.9 GPH
 - Model CF2500:** Tube **KP** — 17.0 to 25.0 GPH
 - Model CF3500A:** Tube **KM** — 17.0 to 35.0 GPH or Tube **KR** — 17.0 to 35.0 GPH
- Maximum firing capacity depends on the firebox pressure. Use **Table 2** to verify the correct air tube type for the firing rate required. (Tube **KR** [CF3500A] is an optional air tube combination for maximum capacity rate. It requires a larger I.D. flange No. 51631.)
- See **Figure 2** to verify the correct air tube length and air tube combination code.

Figure 1 – Min. combustion chamber dimensions

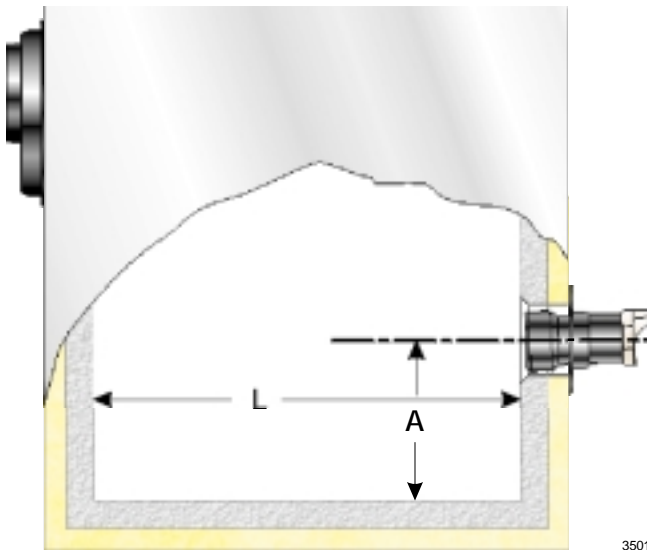

Firing rate	Minimum dimensions	
	(all boilers)	
	A	L
17 gph	10.5"	48.0"
22 gph	11.5"	58.0"
27 gph	12.5"	66.0"
32 gph	12.5"	73.0"
35 gph	13.0"	77.0"

Figure 2 – Air tube mounting dimensions

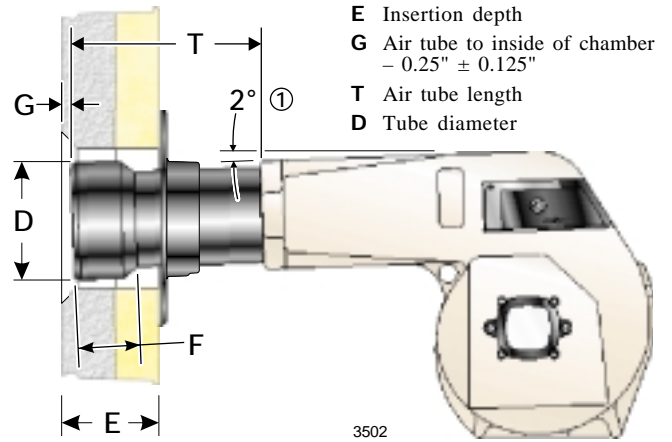

① Install the burner with a 2° pitch as shown.

A.T.C. Codes (A.T.C. = Air Tube Combination)								
CF2500A/ CF2500			CF3500A					
Tube KP			Tube KM			Tube KR		
Dimensions			Dimensions			Dimensions		
T	D	F	T	D	F	T	D	F
All	6 1/2"	3/4"	All	8"	4 1/2"	All	9 15/16"	5 1/8"
6 3/4"	CF	66 KP	8"	CF	80 KM	—	—	—
—	—	—	9 1/4"	CF	92 KM	—	—	—
10 1/4"	CF	102 KP	11 1/2"	CF	114 KM	11 1/2"	CF	114 KR
13 3/4"	CF	136 KP	15"	CF	150 KM	14"	CF	140 KR
17 3/4"	CF	176 KP	19"	CF	190 KM	19"	CF	190 KR

Table 2 – Air tube capacity vs. firebox pressure

Firebox pressure (In. W.C.)	Tube KP		Tube KM/KR	
	No reserve air	10% turndown	No reserve air	10% turndown
	Maximum firing rate GPH			
0.0	25.0	22.5	35.0	31.5
0.2	24.8	22.3	33.5	30.2
0.4	24.6	22.3	32.0	28.8
0.6	24.5	22.1	30.2	27.2
0.8	24.3	21.9	28.8	25.9
1.0	24.1	21.7	27.1	24.4

Note: 10% turndown indicates sufficient reserve air to reduce the CO₂ in the flue to 90% of its value.

Note: The above ratings may vary 5% due to variations in actual job conditions.

Mount the burner

□ Mount flange(s) on air tube

- This section does not apply to burners with welded flanges.
- Do not install air tube on burner.
- For **non-pressure firing flange**, refer to **Figure 3**: Install gasket (item **a**) and flange (item **d**). Ignore the next paragraph.
- For **pressure-firing flange**, refer to **Figure 3**: Slide gasket (item **a**) onto the air tube, making sure the top of the air tube is up. Predrill holes in the pressure firing plate (item **b**) to match the appliance studs. Slide the pressure firing plate (item **b**) and flange (item **d**) onto the air tube as shown. Wrap ceramic fiber rope (item **c**) around the air tube and press tightly into the inside diameter of the flange (item **d**).
- Slide the air tube (item **e**) into position in the appliance front. Tighten the flange-mounting-stud nuts. Set the insertion of the air tube so dimension **G** is 1/4" nominal.
- Pitch the air tube at 2° from horizontal as shown and secure the flange to the air tube. Remove the flange-mounting stud nuts and remove the air tube from the appliance.

Figure 3 - Mount flange(s) on air tube

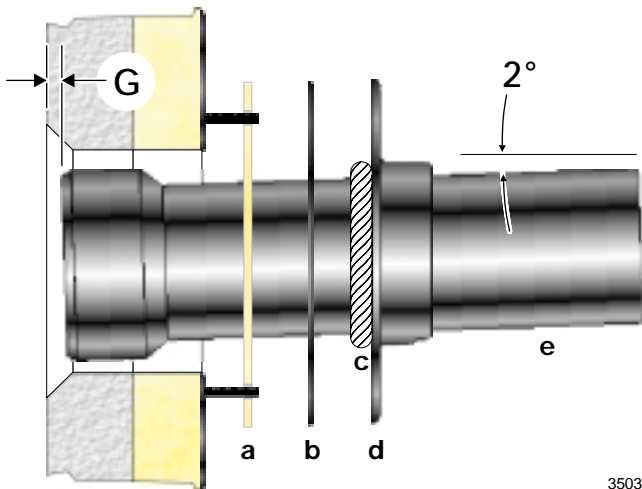

□ Mount air tube to burner

- Remove the rear access door from the back of the burner for improved access to the interior.
- Attach the air tube to the burner with the bolts and acorn nuts provided. The acorn nuts must go on the outside of the burner, with the bolts inserted from the inside.

□ Install nozzle

- See **Figure 4**. Install the oil nozzle in the nozzle adapter. Use a 3/4" open-end wrench to steady the nozzle adapter and a 5/8" open-end wrench to turn the nozzle. Tighten securely but do not overtighten.
- Check, and adjust if necessary, the critical dimensions **P**, **Q**, **R** and **S** shown in the drawing. Verify that the oil tube assembly and electrodes are in good condition, with no cracks or damage.

Figure 4 - Nozzle and nozzle line assembly

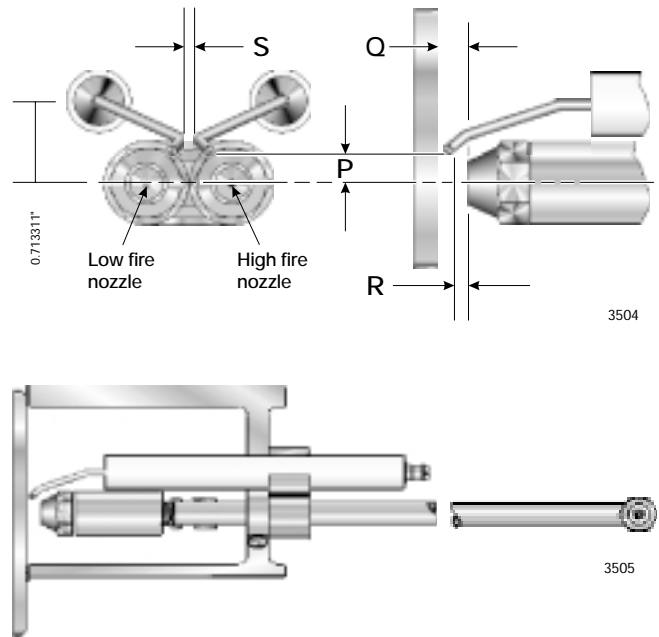

Critical dimensions —

S (Electrode spacing)	= 3/32"	P (Nozzle center line to electrode tip)	= 1/4"
Q (Nozzle to head)	= 1/4"	R (Nozzle face to electrode tip)	= 1/8"

WARNING

Failure to properly set and maintain the electrode and nozzle spacing dimensions can cause incorrect burner ignition or poor combustion. This could result in severe personal injury, death or substantial property damage.

□ Install nozzle line assembly

- Insert the nozzle line assembly into the burner air tube as in **Figure 5**.
- See **Figures 5 and 6**. Assemble the adjusting plate assembly per the instructions in the assembly packet.
- Slide the secondary adjusting plate (item **f**) completely to the left on the indicator adjusting plate (item **e**). Finger-tighten acorn nut **c** to secure the two plates together. Slide both plates completely to the left on the primary adjusting plate (item **g**) and finger-tighten acorn nut **d**.
- Slide the completed adjusting plate assembly over the nozzle line end. Move the plate assembly and the nozzle line so the plate assembly fits into position as shown in **Figure 5**.
- Install the spline nut (**Figure 5**, item **b**) on the end of the nozzle line, leaving the nut loosely placed so the plates can be moved.
- Connect the high-voltage leads from the ignition transformer to the electrodes.

Figure 5 - Nozzle line assembly in burner

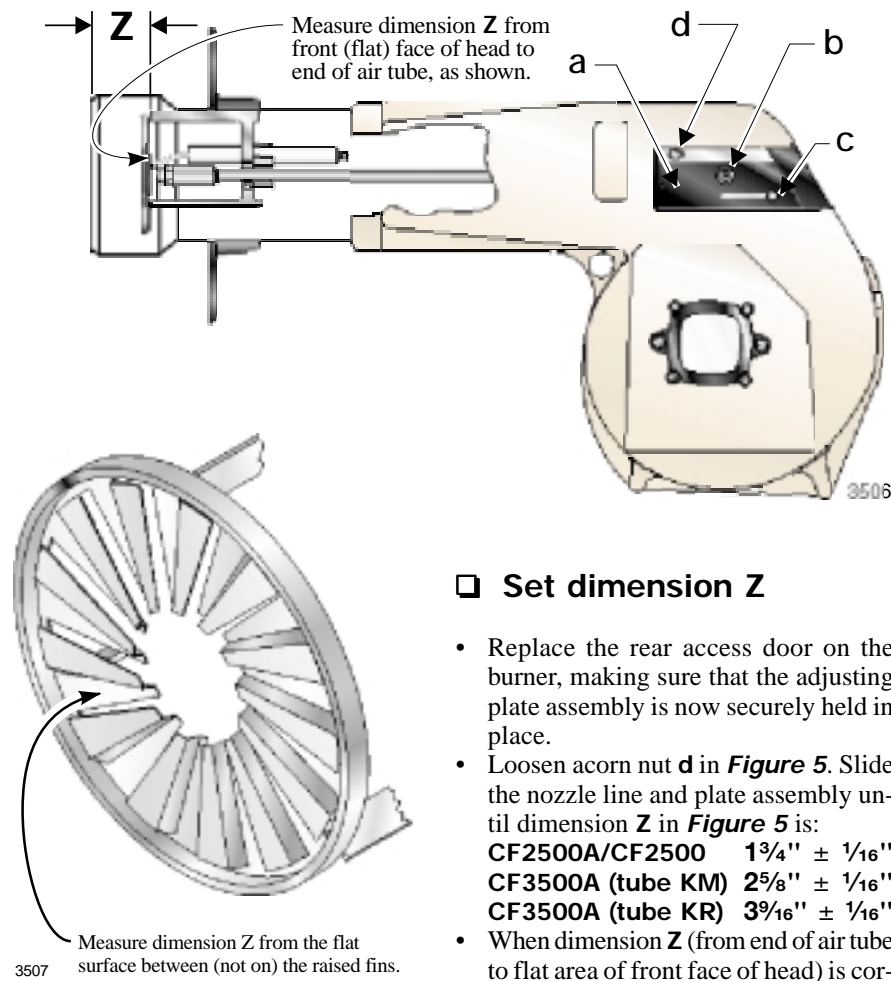

□ Set dimension Z

- Replace the rear access door on the burner, making sure that the adjusting plate assembly is now securely held in place.
- Loosen acorn nut **d** in **Figure 5**. Slide the nozzle line and plate assembly until dimension **Z** in **Figure 5** is:
 - CF2500A/CF2500 $1\frac{3}{4}'' \pm \frac{1}{16}''$
 - CF3500A (tube KM) $2\frac{5}{8}'' \pm \frac{1}{16}''$
 - CF3500A (tube KR) $3\frac{9}{16}'' \pm \frac{1}{16}''$
- When dimension **Z** (from end of air tube to flat area of front face of head) is cor-

Figure 6 - Adjusting plate assy.

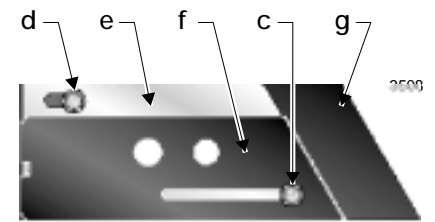

Legend (Figures 5 and 6)

- a** Adjusting plate assembly
- b** Spline nut for securing nozzle line
- c** Bottom acorn nut
- d** Top acorn nut (for setting dim. Z only)
- e** Indicator adjusting plate
- f** Secondary adjusting plate
- g** Primary adjusting plate

- rectly set, tighten acorn nut **d**. Verify that the adjusting plate assembly is properly seated at the rear access door, as shown in **Figure 5**.
- Attach the oil line from the oil valve to the nozzle line end. Tighten securely.
- Before proceeding, check dimension **Z** once again. Loosen acorn nut **d** if necessary to reposition the nozzle line. Once dimension **Z** is set, **do not loosen acorn nut d again**. For the setting of acorn nut **c**, refer to page 12.

Figure 7 - Burner installed in appliance front

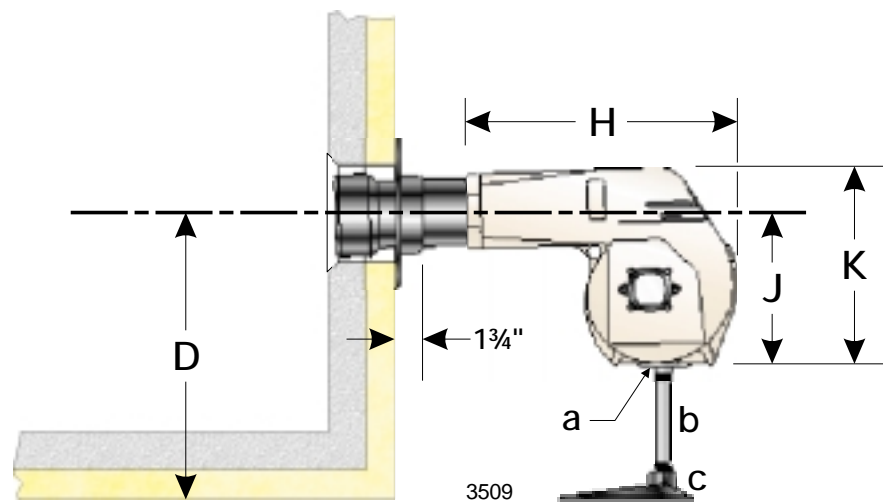

Legend

- H** Housing total length — 20"
- J** Center to bottom of housing — 14½"
- K** Overall housing height — 22¾"

□ Insert burner

- Position the burner in the front of the appliance and loosely tighten the nuts on the mounting studs. The burner should be pitched downward 2° as shown in **Figures 3 and 7**.
- See **Figure 7**. Install the pedestal support kit (recommended) by attaching the ¾" npt flange (item **a**) to the bottom of the burner using the (4) #10 screws provided. Cut and thread (one end only) a ¾" pipe nipple (item **b**) with length **14.5 inches less than dimension D** in **Figure 7**. Thread the pipe into the flange. Then slip the pipe end into the floor flange (item **c**).
- Secure the burner to the appliance by tightening the nuts on the burner flange mounting studs. Then secure the pedestal support floor flange set screw to the pipe.

Connect fuel line(s)

WARNING

- Install the oil lines using the following guidelines. Failure to comply could lead to equipment damage and present a risk of severe personal injury, death or substantial property damage due to leakage of oil and potential fire hazard.
- Use only flare fittings at joints and connections. Never use compression fittings.
- Install fittings only in accessible locations to assure any leak will be detected.
- Where joint sealing is needed, use only pipe dope. Never use Teflon tape. Tape strands can break free and damage the fuel unit.
- Never use a one-pipe oil system with a lift in excess of 2 feet with an **H** fuel unit. On two-pipe oil systems, verify that the suction line vacuum does not exceed the fuel unit manufacturer's recommendation.

Fuel unit by-pass plug

WARNING

The CF2500A, CF2500 and CF3500A burners are shipped without the by-pass plug installed. You **must** install this plug on two-pipe systems. **DO NOT** install the by-pass plug in the fuel unit if connected to a one-pipe oil system. Failure to comply could cause fuel unit seal failure, oil leakage and potential fire and injury hazard.

Oil supply/return lines

- Install the oil tank and oil lines in accordance with all applicable codes.
- Size the oil supply and return lines using the guidelines given in the fuel unit literature included in the literature envelope. Oil line flow rate will equal the burner rate for one-pipe systems. For two-pipe systems, refer to **Table 3** for the fuel unit gearset capacity - the rate at which fuel is recirculated when connected to a two-pipe system. Size two-pipe oil lines based on this flow rate.
- Use continuous lengths of heavy-wall copper tubing, routed under the floor where possible. Do not attach fuel lines to the appliance or to floor joists if possible. This reduces vibration and noise transmission problems
- Install an oil filter sized to handle the fuel unit gearset flow capacity (**Table 3**) for **two-pipe systems**. Size the filter for the firing rate for **one-pipe systems**. Locate the filter immediately adjacent to the burner fuel unit.

Figure 8a
One-pipe oil flow, one nozzle, low fire, "H" pump

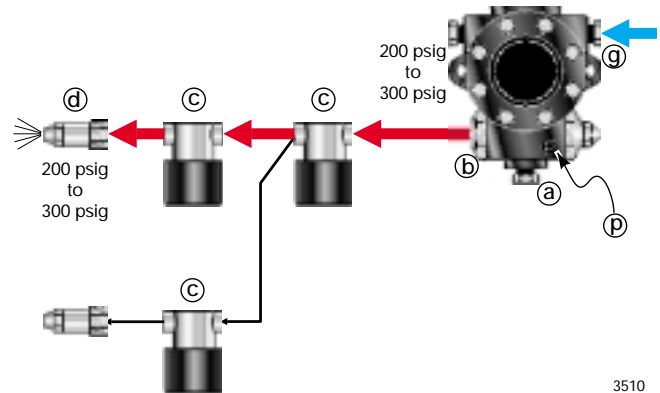

3510

Figure 8b
One-pipe oil flow, two nozzles, high fire, "H" pump

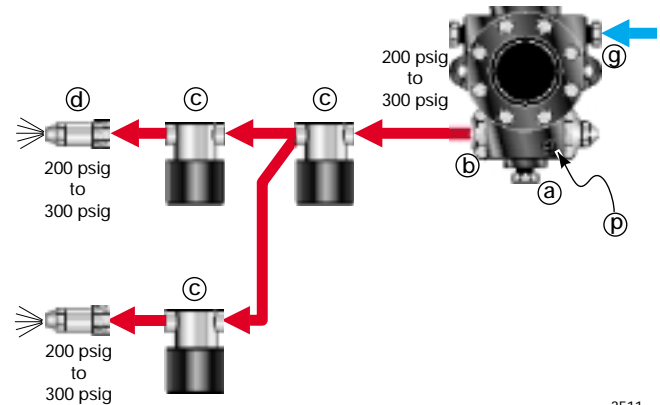

3511

Legend (see opposite page)

Table 3 - Fuel unit gearset capacities

Fuel unit model number	Gearset capacity (gallons per hour)
H5PAN-C100H	79

Figure 9a
Two-pipe oil flow, one nozzle, low fire, "H" pump

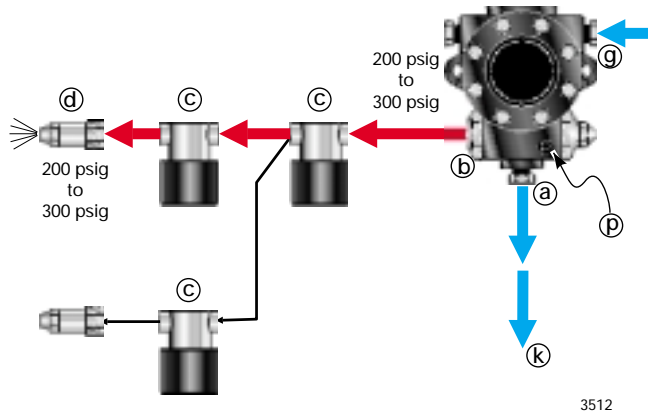

3512

Figure 9b
Two-pipe oil flow, two nozzles, high fire, "H" pump

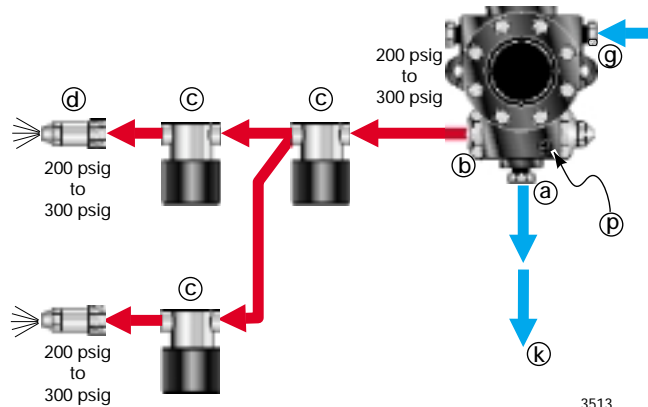

3513

Legend (for Figures 8a, 8b, 9a and 9b)

- a Return port
- b Nozzle port
- c Oil valves
- d Nozzle & adapter
- g Inlet port
- k Return line to oil tank
- p Air bleed valve

- Install two high-quality shutoff valves in accessible locations on the oil supply line. Locate one valve close to the tank. Locate the other valve close to the burner, upstream of the fuel filter.

□ Burner fuel flow

- **One-pipe systems** – See **Figure 8** for the fuel flow paths for high-fire and low-fire operation. Oil supply connects to one of the fuel unit Inlet ports.

WARNING Do not install by-pass plug in a one-pipe system. Could cause unit seal failure, oil leakage and potential fire and injury hazard if ignored.

- **Two-pipe systems** – See **Figure 9** for the fuel flow paths for high-fire and low-fire operation. Oil supply connects to one of the fuel unit Inlet ports. Oil return connects to the fuel unit Return port.

WARNING By-pass plug **must** be installed in a two-pipe system. Failure to comply could cause unit seal failure, oil leakage and potential fire and injury hazard.

- **Low-fire/high-fire operation** – The fuel unit nozzle port pressure is factory set at 300 psig.
 - At high fire, full pressure (300 psig) is applied at both oil nozzles, causing full input.
 - At low fire, full pressure (300 psig) is applied at one nozzle, causing reduced input.

Wire the burner

WARNING Do not by-pass any safety control. By-passing a safety control could result in severe personal injury, death or substantial property damage.

Install the burner and all wiring in accordance with the National Electrical Code and all applicable local codes or requirements.

Wire the burner in compliance with all instructions provided by the appliance manufacturer. Verify operation of all controls in accordance with the appliance manufacturer's guidelines.

See **Figure 10** for a typical wiring diagram for a CF2500A

burner, with R8184 oil primary, for reference purposes only. The CF2500/CF3500A burner is available with many different wiring configurations. Refer to the wiring diagram shipped with the burner for the actual wiring applying to your burner.

When firing over 20 GPH, the CF2500 and CF3500A will be supplied with a flame safeguard control. An airflow switch and low-fire start switch may also be supplied. Consult local, state and federal codes for burner requirements above 20 GPH.

Figure 10 - CF2500A Typical wiring

Legend

- FD** Fused disconnect, by others
- LM** Limit controls, by others
- OP** Operating controls, by others
- PR** Oil primary control, R8184 typical
- CC** Flame sensor, cad cell typical
- TM** Optional delay timer
- TR** Ignition transformer
- M1** Burner motor
- S1** Primary oil valve
- S2** High-fire valve
- S3** Redundant oil valve
- DM** Damper motor and end switch
- * H/L** Insert high/low-fire control here
- LFHS** Low-fire hold switch
- T-T** 24-volt thermostat/limit terminals
- F-F** Cad cell flame sensor terminals

Note 1 — Indicates alternate wiring for interrupted ignition controls — connect transformer to blue primary lead. For intermittent duty — connect transformer to orange primary lead only.

WARNING

Electrical shock hazard - can cause injury or death. Disconnect power before installing or servicing. Provide ground wiring to the burner in accordance with the National Electrical Code.

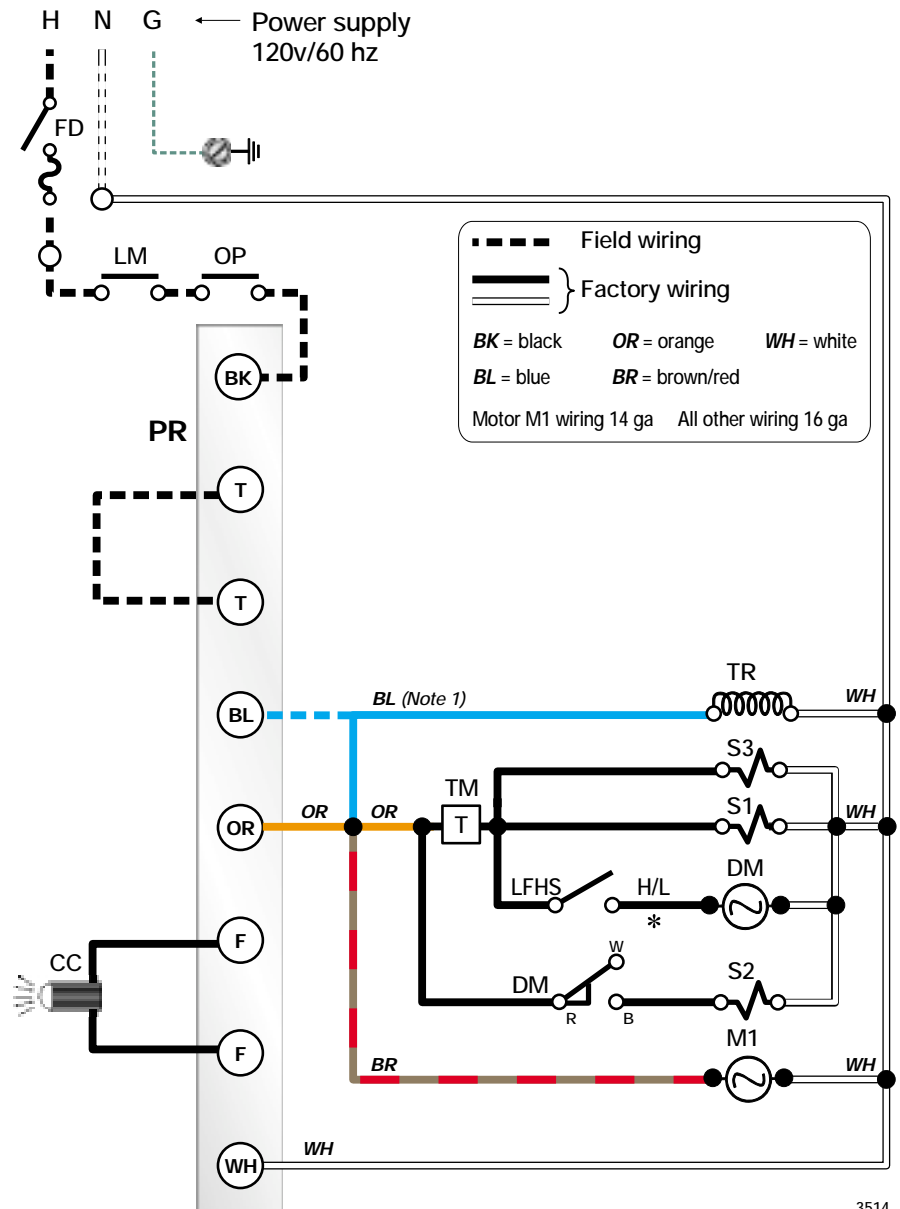

3514

Sequence of operation — typical

1. On call for heat from the appliance operating controls (and the circuit from **T** to **T** of the R8184 closed), power is applied to the R8184 black wire (**BK**).
2. The R8184 applies 120 volts to the orange wire (**OR**), activating the burner motor (**M1**) and the ignition transformer (**TR**). The oil pump is operated by the burner motor, so oil pressure is delivered to the oil valve inlets.
3. Power is applied to the oil valve circuit. If optional timer, (**TM**), is installed, oil flow will be delayed for the timer duration, thus providing a prepurge period. When the timer times out, oil valves **S1** and **S3** are activated, allowing oil to flow to the low-fire nozzle.
4. With the low-fire hold switch (**LFHS**) in the “**IN**” position, the burner will remain at low fire.
5. When the low-fire hold switch is moved to the “**OUT**” position, the damper motor (**DM**) will be activated. This will begin opening the air damper.
6. When the damper motor end switch is tripped, high-fire oil valve (**S2**) is activated, providing pressure at the high-fire oil nozzle. With both nozzles firing, the burner is now at high fire. The damper motor end switch is set to operate **before** the damper has reached full open to assure a smooth transition to high fire.
7. If a high/low-fire control is installed at **H/L**, this control will cycle the firing rate automatically during an operating cycle.
8. At the start of the cycle, the R8184 begins checking for flame signal between **F** and **F**. Flame must be established within 15 seconds of initiation. If no flame is sensed after 15 seconds, the R8184 will terminate all power to the blower and oil circuits, shutting the burner down. The control will electrically lock out.
 - To reset the control after lockout, wait 2 to 3 minutes after lockout to give the internal switch time to cool. Then push the reset button on the primary control, allowing the burner to operate in normal sequence.
 - Troubleshoot the reason for flame sense failure.
9. When the call for heat signal terminates (at the black wire of the R8184), the R8184 terminates power to all circuits, closing the oil valves and stopping the burner motor.

Prepare the burner for start-up

Start-up checklist – *Verify the following before attempting to start burner.*

- | | |
|----------------------------------------------------------------------------------------------------------------------------------------------------------------------------------------------------------------------------------------------------------------------------------------------------------------------------------------------------------------------------------------------------------------------------------------------------------------------------------------------------------------------------------------------------------------------------------------------------------------------------------------------------------------------------------------------------------------------------------------|-------------------------------------------------------------------------------------------------------------------------------------------------------------------------------------------------------------------------------------------------------------------------------------------------------------------------------------------------------------------------------------------------------------------------------------------------------------------------------------------------------------------------------------------------------------------------------------------------------------------------------------------------------------------------------------------------------------------------------------------------------------|
| <ul style="list-style-type: none"> <input type="checkbox"/> Combustion air supply and venting have been inspected and verified to be free of obstructions and installed in accordance with all applicable codes. <input type="checkbox"/> Oil nozzles have been selected correctly and securely installed in the nozzle adapter. <input type="checkbox"/> Fuel unit by-pass plug is installed for two-pipe oil systems. (Do not install by-pass plug for one-pipe systems.) <input type="checkbox"/> Fuel connection to nozzle line assembly is secure. <input type="checkbox"/> Dimension Z has been set per this instruction manual. See Set dimension Z on page 7. | <ul style="list-style-type: none"> <input type="checkbox"/> Fuel supply line is correctly installed, the oil tank is sufficiently filled, and shutoff valves are open. <input type="checkbox"/> Burner is securely mounted in appliance, with pressure firing plate and gasket installed for pressurized chamber application. <input type="checkbox"/> Appliance has been filled with water (boilers) and controls have been operationally checked. <input type="checkbox"/> Burner has been installed in accordance with appliance manufacturer’s instructions (when available). <input type="checkbox"/> Also refer to appliance manufacturer’s instructions (when available) for start-up procedures. |
|----------------------------------------------------------------------------------------------------------------------------------------------------------------------------------------------------------------------------------------------------------------------------------------------------------------------------------------------------------------------------------------------------------------------------------------------------------------------------------------------------------------------------------------------------------------------------------------------------------------------------------------------------------------------------------------------------------------------------------------|-------------------------------------------------------------------------------------------------------------------------------------------------------------------------------------------------------------------------------------------------------------------------------------------------------------------------------------------------------------------------------------------------------------------------------------------------------------------------------------------------------------------------------------------------------------------------------------------------------------------------------------------------------------------------------------------------------------------------------------------------------------|

Prepare the burner for start-up - continued

❑ Z dimension

- Should be set per these instructions (see page 7). The top acorn nut (**Figure 11**, item **d**) should never be loosened once the **Z** dimension is initially set.

❑ Adjusting plate assembly (**Figure 11**)

- Make sure spline nut (item **b**) and bottom acorn nut (item **c**) are loose.

❑ Initial head position (**Figure 11**)

- The indicator plate assembly (item **e**) markings correspond to head position settings.
- Slide the secondary adjusting plate (item **f**) toward the rear of the burner until the number on the indicator plate corresponds to the initial head setting given in **Table 4** for the desired firing rate (**high-fire**).
- **Figure 11** shows a typical example, with a head setting of 5.
- When the head position has been set, tighten the bottom acorn nut (item **c**) and the spline nut (item **b**).

❑ Initial air settings (**Figure 12**)

- Loosen the screw holding the air adjusting plate (item **m**). Set the air to the desired **low-fire** rate. (The numbers on this plate correspond to the approximate firing rate settings given in **Table 5**.)
- Rotate the air adjusting plate until the lower edge of the pointer is opposite the number from **Table 5** corresponding to the desired **low-fire rate**.
- This initial setting should be adequate for starting the burner at low fire. Once the burner is in operation, the air setting will be adjusted for best performance as discussed later in this manual.
- The damper moves to high-fire position as the damper rod (item **d**) rotates the damper linkage arm (item **f**). You will adjust the setting of the damper linkage arm when setting the high-fire air as discussed on page 14 in **Start the burner**.
- Follow the procedures given later in this manual for fine tuning the air settings.

❑ Set appliance limit controls

- Set the appliance limit controls in accordance with the appliance manufacturer's recommendations.
- Move the low-fire hold switch (not shown) to the "IN" position. This will hold the burner in low fire during initial start-up.

Figure 11 – Adjusting plate initial setting, typical

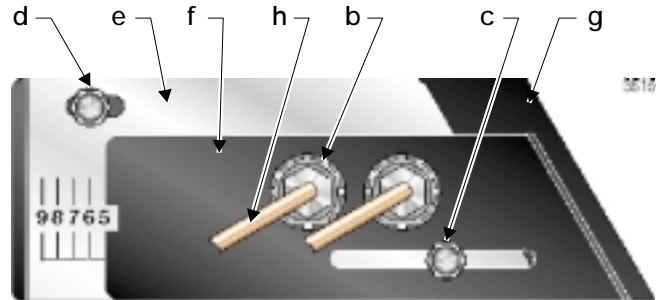

Legend

- | | |
|--------------------------------------------------------------------------------------------------------|--------------------------------------------------------|
| b Spline nut for securing nozzle line | f Secondary adjusting plate |
| c Bottom acorn nut (for head adjustments) | g Primary adjusting plate |
| d Top acorn nut (for setting dim. Z only — do not loosen after setting Z) | h Copper oil line from oil valve to nozzle line |
| e Indicator adjusting plate | |

❑ Prepare the fuel unit for air venting

- To vent air from one-pipe oil systems, attach a clear hose to the vent plug on the fuel unit. Provide a container to catch the oil. Loosen the vent plug.
- Vent the air as described under **Start the burner**, page 14.

Table 4 – Initial indicator adjustment plate settings (head position)

Approximate head settings	Firing rate, gph	
	Tube "KP"	Tube "KM"/"KR"
0	--	--
1	--	17.00
2	--	17.50
3	17.00	18.00
4	17.50	18.50
5	18.00	19.00
6	18.50	20.00
7	19.00	21.00
8	20.00	28.00
9	21.00	32.00
10	25.00	35.00

Figure 12 – Air damper and damper motor assembly

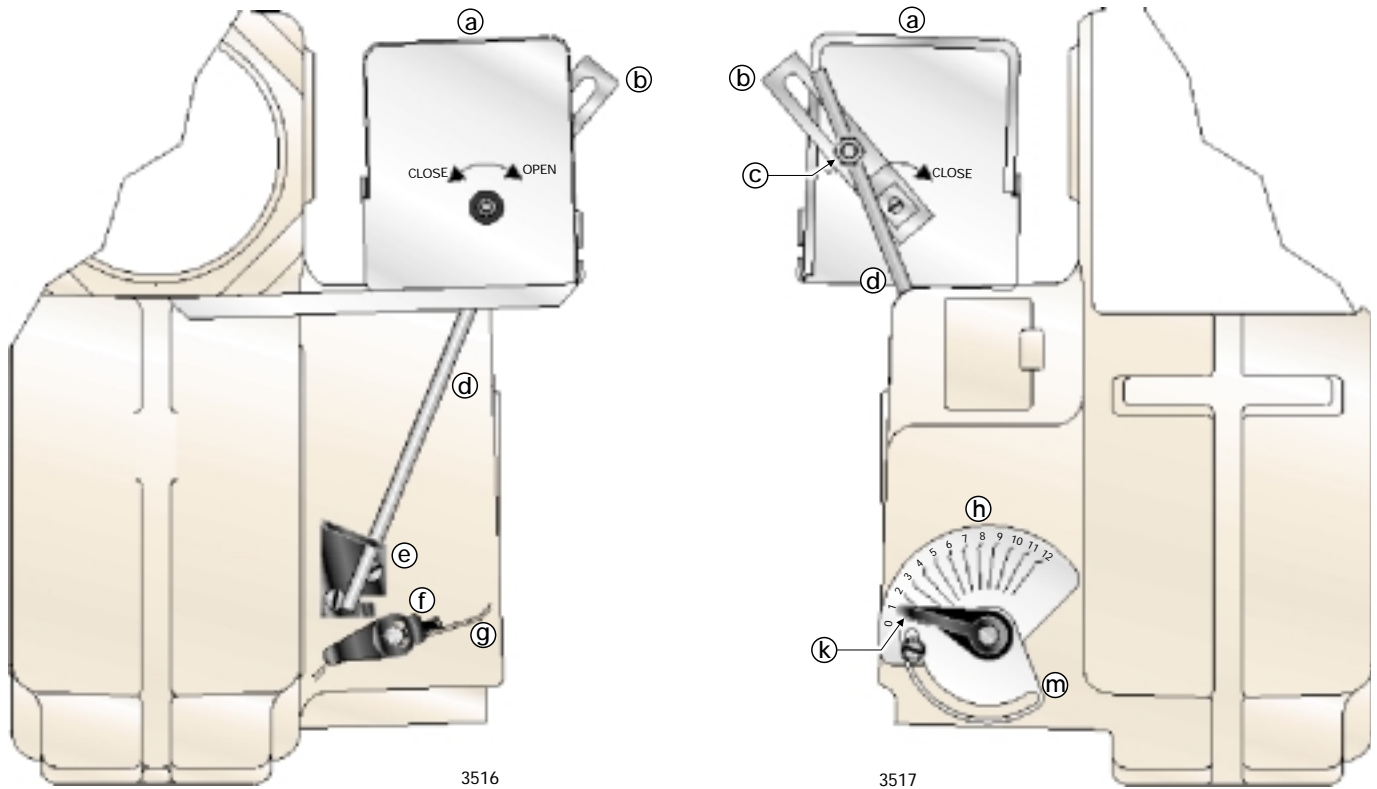

Table 5 – Initial air adjusting plate settings (damper position)

Approximate adjusting plate settings	Firing rate, gph	
	Tube "KP"	Tube "KM"/"KR"
0	--	--
1	8.00	8.00
2	9.00	9.00
3	11.00	11.00
4	12.00	12.00
5	15.00	15.00
6	17.00	17.00
7	18.00	19.00
8	19.00	22.00
9	20.00	25.00
10	22.00	29.00
10.5	25.00	35.00

Legend (Figure 12)

- a Damper motor – *do not adjust internal cam*
- b Arm assembly
- c Ball joint assembly – *do not adjust position of ball joint*
- d Damper rod
- e Damper rod guide
- f Damper linkage arm - sets *high-fire* air position
- g Damper
- h Damper label - position indicator for air adjusting plate
- k Damper indicator - permanently attached to damper
- m Air adjusting plate - sets *low-fire* air position

Start the burner

WARNING

Do not proceed unless all prior steps in this manual have been completed. Failure to comply could result in severe personal injury, death or substantial property damage.

WARNING

Do not attempt to start the burner when excess oil has accumulated, when the appliance is full of vapor or when the combustion chamber is very hot. Do not attempt to reestablish flame with the burner running if the flame should be extinguished during start-up, venting or adjustment. Allow the unit to cool off and all vapors to dissipate before attempting another start. Failure to comply with these guidelines could cause an explosion or fire, resulting in severe personal injury, death or substantial property damage.

WARNING

Damper motor and motor arm assembly - Do not attempt to adjust the cam setting in the damper motor. It is factory preset. Do not move the ball joint assembly further out on the motor arm assembly. This would change the timing of damper opening versus fuel rate. The damper linkage arm screw must be tightened securely to assure the damper will provide sufficient air at high fire. Failure to comply could cause unreliable combustion or flame failures, leading to possible severe personal injury, death or substantial property damage.

□ Start burner and vent air from oil line

1. Move the low-fire hold switch to the “IN” position (to hold burner in low fire when started).
2. Verify that the air adjusting plate (*Figure 12*, item **m**) has been set to the initial *low-fire* air position as described on page 12 under *Initial air settings*.
3. Loosen the screw on the damper linkage arm (*Figure 12*, item **f**) and allow the damper indicator (*Figure 12*, item **k**) to rest on the air adjusting plate (*Figure 12*, item **m**).
4. Open the oil shutoff valves in the oil supply (and return) line(s) to the burner.
5. Set the thermostat (or operating control) to call for heat.
6. Close the line switch to the burner. The burner motor should start immediately.
7. If the burner motor does not start, reset the motor overload switch (if so equipped) and press the reset switch of the burner primary control.
8. Vent the fuel unit as soon as the burner motor starts rotating. To vent —
 - Attach a clear plastic tube to the air bleed valve (*Figure 8a, 8b, 9a or 9b* as applies, item **p**).

- Place the end of the tube in a container to catch the oil. Then loosen the fuel unit air vent valve.
- Tighten the air vent valve after all air has been purged.
- *IF burner stops during venting*—
 - The burner primary control will lockout if flame is not established within its time limit. This is typically 15 seconds for R8184 primary controls, but may be less for other flame supervisory controls.
 - The burner may lockout several times during the period needed to purge all the air. Reset the primary control each time in order to continue purging.
 - If the burner is equipped with an R8184 primary, you will need to wait about 2 minutes after each lockout to allow time for the reset switch to cool.
 - Squeeze off the air bleed tubing or close the air vent valve when the pump stops running to prevent air from flowing back into the oil line.

If the fuel unit air vent valve is *completely open*, assuring no flow of oil to the burner oil nozzle, you can *temporarily* jumper the *F-F* terminals of an R8184 primary during the purge period to allow enough time for all air to purge. *Never leave the burner unattended when doing this*. Remove the jumper when purging is completed. **This procedure should only be used by a qualified burner technician, experienced in burner operation and control.** Improper application of this method can cause combustion chamber explosion, fire hazard or fuel leakage, resulting in severe personal injury, death or substantial property damage.

□ *IF burner stops after flame established*—

- Additional venting is probably required. Repeat the air venting procedure.
9. Once flame is steady, proceed to *Set high-fire air*.

□ Set high-fire air

1. Allow the burner to run at low fire until the appliance has warmed sufficiently.
2. Visually check the flame. The flame should not be dark orange or smoky. If the flame appears to be smoking, increase the amount of air by readjusting the damper indicator to a higher number.
3. Once the appliance has warmed, the high-fire setting can be checked and adjusted.
4. Locate the approximate air adjusting plate setting for *high fire* in *Table 5*, page 13.
5. Place the low-fire hold switch in the “OUT” position. The damper motor will begin to rotate.
 - a. At the same time, loosen the screw securing the air adjusting plate (*Figure 12*, item **m**) as the damper begins to move.

- b. Slowly rotate the air adjusting plate (increase the amount of air) as the damper drives to high-fire.
 - c. Lock down air adjusting plate at the **high-fire** air setting found in **Table 5** for the **high-fire** rate.
6. Use combustion test instruments to adjust the burner.
 - a. Adjust the air until a trace of smoke is achieved with CO₂ level as high as possible (lowest possible O₂).
Example: 13.5% CO₂ (2.5% O₂) with a trace of smoke.
 - b. Increase the air to reduce CO₂ by 2 percentage points at a zero smoke level. (Increase O₂ by 3 percentage points at a zero smoke level.)
Example: Reduce CO₂ from 13.5% to 11.5%, with zero smoke (or increase O₂ from 2.5% to 5.5%).
 - c. A margin of reserve air has been added to accommodate variable conditions.
 7. Check the breech draft pressure against the appliance manufacturer's recommended setting (typically + 0.1" W.C.).
 8. If the breech pressure is higher or lower than recommended level, adjust the appliance breech damper to achieve the specified setting. Recheck the smoke and CO₂ levels. Adjust burner air if necessary.
 9. Once all settings are complete and satisfactory, rotate the damper linkage arm (**Figure 12**, item **f**) until it touches the damper rod (**Figure 12**, item **d**) and tighten the damper linkage arm screw securely.

❑ Set low-fire air

1. Loosen the air adjusting plate (**Figure 12**, item **m**) screw and set the air adjusting plate at the **low-fire** air setting found in **Table 5**, page 13. The damper should stay at the high-fire setting. The damper linkage will prevent movement of the damper plate.
2. Move the low-fire hold switch from the "OUT" to the "IN" position.
 - a. The damper will return to the **low-fire** air setting.
3. Check the smoke and CO₂ (O₂) levels.
 - a. Pull a smoke sample from the flue.
 - b. The sample should be clean (zero smoke level).
 - c. Check the CO₂ (O₂) level:
CO₂ should be at 11 to 12% (O₂ at 5.9 to 4.5%).

If the CO₂ is less than 11% (O₂ more than 5.9%), decrease the air and check the smoke level.
4. Operate the burner from low fire to high fire and back to verify operation.
5. Turn the burner off. Wait one or two minutes (for chamber to clear) and then turn on again to verify starting characteristics.
6. Perform limit circuit performance test specified by appliance manufacturer to verify operation of burner/appliance combination.

Maintenance and service

WARNING

The burner must be serviced at least annually by a qualified service technician to assure continued reliable operation. Operation and adjustment of the burner requires technical knowledge and the use of combustion test instruments. Do not tamper with the burner or controls. Failure to comply could result in failure of the burner or system, resulting in severe personal injury, death or substantial property damage.

Annual service

— by qualified service technician

Have the burner inspected, tested and started at least annually by a qualified service technician. This annual test/inspection should include at least the following:

- ❑ Replace oil nozzles.
- ❑ Clean burner and blower wheel (if needed to remove lint or debris).
- ❑ Test ignition and combustion at low and high fire and verify air damper settings.
- ❑ Test oil supply line vacuum - verify that it is within allowable range indicated in fuel unit literature.
- ❑ Check pump pressure to nozzles at low and high fire.
- ❑ Inspect fuel system (including tank, lines and all connections).

- ❑ Inspect combustion air and vent systems.
- ❑ Replace oil filter.
- ❑ Oil motor (if not permanently lubricated).

Monthly maintenance

— by owner

- ❑ Observe combustion air openings and vent system for integrity. Openings must be clean and free of any obstructions.
- ❑ Check the oil lines and fittings to verify there are no leaks.
- ❑ Observe burner ignition and performance to verify smooth operation.
- ❑ Shut the system down if you observe abnormal or questionable operation. Call a qualified service agency for professional inspection and service.

Replacement parts

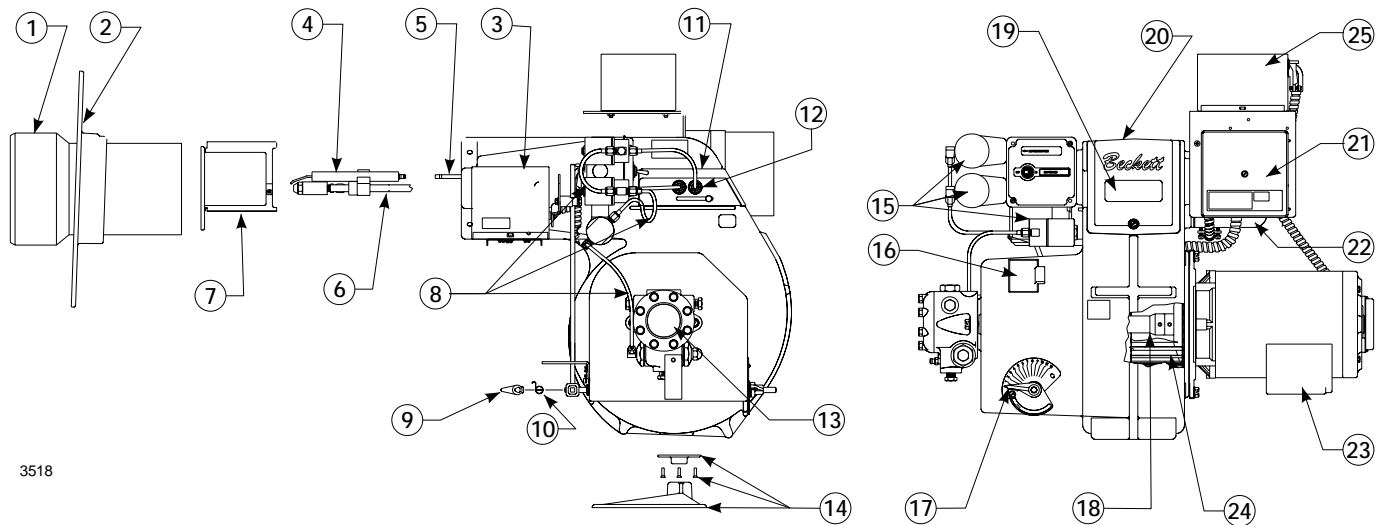

3518

Item	Part name	Description	Part number
1	Air tube	Specify burner model and tube length (See <i>Figure 2, page 5</i> for codes)	
2	Flange kit	Adjustable flange	See <i>Figure 13</i>
3	Damper motor assembly	All models	51229
4	Electrode assembly	All models	51212
5	Ignition leads	9 ¼" long	5990092
		10 ½" long	5990104
		12 ¾" long	5990126
		16 ¼" long	5990162
		20 ¼" long	5990202
6	Nozzle line assembly	Specify burner model and air tube length	
7	Head assembly	CF2500/CF3500A	51475P
8	Fuel lines	Specify length	

Item	Part name	Description	Part number
9	Damper linkage arm	All models	5984BK
10	Damper spring	All models	4339
11	Adjusting plate assembly	All models	51478
12	Knurled nut	All models	3666
13	Fuel pump	H pump (standard)	21529
14	Pedestal kit	All models	51193
15	Oil valve	Box mounted	7201
16	Damper door	All models	16703GY
17	Damper indicator	All models	5985BK
18	Coupling	Specify pump used	
19	Sight glass	All models	31346
20	Rear cover assembly	CF2500/CF3500A	51204
21	Control	Specify	
22	Transformer	12,000 volt	51214
23	Motor	Specify burner model	
24	Blower wheel	CF2500/CF3500A	21528
25	Motor relay	Specify relay used	

Figure 13
Adjustable mounting plates for CF2500/CF3500A

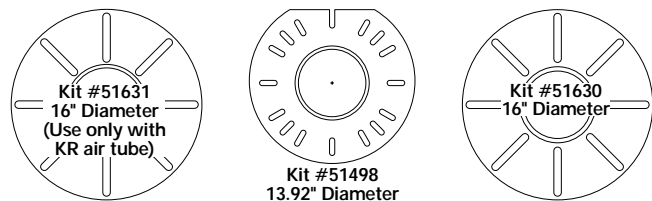

R.W. BECKETT CORPORATION

U.S.A.: P.O. Box 1289 • Elyria, Ohio 44036 • 800-645-2876 • 440-327-1060 • FAX 440-327-1064

Canada: R. W. Beckett Canada, Ltd. • 430 Laird Road • Guelph, Ontario, N1G 3X7 • 800-665-6972 • FAX 519-763-5656

